

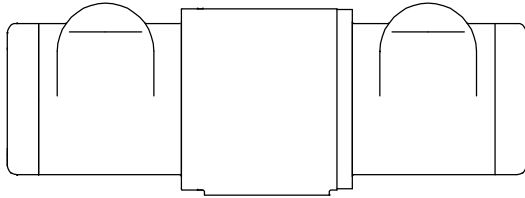

Documentazione guaina Tube assembly documentation Documentation gaine équipée

C52



Nr. di matricola
Housing No.
No. de série

CE 0051

Questa documentazione deve essere fornita all'utilizzatore del complesso tubo guaina
The contents of this documentation must be transmitted to the user of the tube-assembly
Le contenu de cette documentation doit être transmis à l'utilisateur de la gaine équipée

Documentazione N° Documentation N° N° de Documentation	Revisione Edition Version	Data di edizione Date of release Date de l'édition	Testo originale Original text Texte original
C52	B	13.3.2000	italiano / italian / italien



Sommario - Table of contents - Table des matières

Sommario - Table of contents - Table des matières	2
Descrizione - Description - Description	3
Caratteristiche - Specifications - Spécifications.....	4
Dati dello statore - Stator data - Données du stator	5
Curve di riscaldamento e raffreddamento della cuffia Tube-assembly heating and cooling curves Courbes d'échauffement et refroidissement de la gaine équipée	7
Dimensioni - Outline drawing - Schéma dimensionnel.....	8
Collegamenti statore - Stator connections - Connexions du stator	10
Modifiche alla filtrazione - Modification of filtration - Modification de la filtration	11
Accessori - Accessories - Accessoires	12
Simbologia - Symbols - Symboles.....	16
Posizione macchie focali e rotazione anodo Focal spots position and anode rotation Position des foyers et rotation d'anode.....	16
Angolazione caminetti - Housing horn angles - Orientation des embases H.T.....	16

Dichiarazione di conformità

Questo prodotto soddisfa i requisiti essenziali della direttiva 93/42/CEE in accordo alle norme EN 60601.1.3 (IEC 601.1.3) e EN 60601.2.28 (IEC 601.2.28).

Declaration of conformity

This tube fulfils the essential requirements of the directive 93/42/EEC according to standard EN 60601.1.3 (IEC 601.1.3) e EN 60601.2.28 (IEC 601.2.28).

Déclaration de conformité

Ce tube remplit les exigences essentielles de la directive 93/42/CEE en accord avec les normes EN 60601.1.3 (IEC 601.1.3) e EN 60601.2.28 (IEC 601.2.28).

Descrizione - Description - Description

Materiale

Corpo in alluminio rivestito internamente da uno strato di piombo. La cuffia è riempita sottovuoto con olio isolante di particolari proprietà dielettriche, opportunamente trattato.

Material

Lead lined aluminium body. Filled under vacuum with insulating oil, specially processed.

Matériau

Le corps de la gaine est en alliage léger revêtu intérieurement de plomb. Il est rempli, sous vide, d'huile isolante spécialement traitée.

Finitura

Bianco lucido.
Altri colori a richiesta.

Finish

Glossy white.
Other colours by request.

Finition

Blanc brillant.
Autres couleurs sur demande.

Compatibilità

Adatta per inserti con diametro anodico massimo di 90 mm.

Compatibility

Suitable for inserts with max. Anode diameter of 90 mm.

Compatibilité

Adaptée pour inserts ayant un diamètre anodique max. de 90 mm.



Caratteristiche - Specifications - Spécifications

Lunghezza totale Overall length Longueur totale	484 mm	
Diametro massimo Max. diameter Diamètre maximal	170 mm	
Peso netto del complesso tubo-guaina Tube assembly net weight Poids net de la gaine équipée	21 kg	
Limiti di temperatura per il trasporto e lo stoccaggio Temperature limits for transportation and storage Limites de température pour le transport et le stockage	-10°C ÷ +80°C	
Limiti di umidità per il trasporto e lo stoccaggio Humidity limits for transportation and storage Limites d'humidité pour le transport et le stockage	max. 80%	
Alta tensione nominale Nominal X-Ray tube assembly voltage Haute tension nominale de la gaine équipée	150 kV	
Alta tensione verso massa High voltage to ground Haute tension par rapport à la masse	± 75 kV	
Massima energia accumulabile nel complesso tubo-guaina Maximum tube assembly heat content Chaleur maximale retenue dans la gaine équipée	1280 kJ	
Dissipazione termica continua massima senza ventilatore Maximum continuous heat dissipation without fan Dissipation thermique continue maximale sans ventilateur	230 W	
Dissipazione termica continua massima con ventilatore Maximum continuous heat dissipation with fan Dissipation thermique continue maximale avec ventilateur	370 W	
Minima filtrazione inerente nel complesso tubo-guaina Min. tube assembly inherent filtration Min. filtration inhérente de la gaine équipée	1.2 mm Al / 75 kV	(IEC 522)
Filtrazione addizionale Additional filtration Filtration additionnelle	0.3 mm Al	
Filtrazione totale minima Min. total filtration Min. filtration totale	1.5 mm Al eq	
Fattori di carico per la misura della radiazione di fuga Loading factor for leakage radiation determination Paramètres de charge pour la mesure du rayonnement de fuite	150 kV 4.4 mA	(IEC 601.1.3 EN 60601.1.3)
Radiazioni di fuga massima a 1 metro dalle macchie focali Maximum leakage radiation at 1 m from focal spots Rayonnement de fuite maximal à 1 m du foyer	0.44 mGy/h (50 mR/h)	



Dati dello statore - Stator data - Données du stator

Alimentazione / Operation / Alimentation		50 Hz		170 Hz	
		lancio - start - démarrage	mant. - run - maintien	lancio - start - démarrage	mant. - run - maintien
P-C (2-1)	V	220	40	440	100
P = 2	A	7.1	1.3	5.7	0.9
A = C2	A	3.5	0.8	8.2	1.4
C = 1	A	7.8	1.5	9.2	2.1
Capacità del condensatore Condenser capacity Capacité du condensateur		25 - 40 μ F		4.5 μ F	
Max. numero di lanci Max. starting cycles Max. nombre de démarrages		2 / min		1 / min	
Energia e potenza immessa dallo statore Stator input energy and power Energie et puissance introduites par le stator		1550 J	60 W	4860 J	210 W
Valori indicativi: possono variare con il tipo di starter Indicative values: may change with the starter type Valeurs indicatives: peuvent varier avec le type de démarreur					

Resistenza degli avvolgimenti
Windings resistance values
Résistance des enroulements

principale:
phase: 20 Ω
principal:
ausiliario:
phase shift: 40 Ω
auxiliaire:

Tubo / Insert / Tube	Tempi di lancio Starting time Temps de démarrage		Tempi di frenatura Braking time Temps de freinage
	2800/3400 min^{-1}	10000 min^{-1}	
X40	0.6 sec	-	-
RTM78	0.6 sec	0.8 sec	1.6 sec
X50	0.7 sec	-	-
RTM 90/92	0.9 sec	1.2 sec	2.4 sec
Valori indicativi: possono variare con il tipo di starter Indicative values: may change with the starter type Valeurs indicatives: peuvent varier avec le type de démarreur			

<u>Classificazione</u>	<u>Classification</u>	<u>Classification</u>	
Classe di protezione IEC601-1	IEC 601-1 equipment class	CEI 601-1 appareil de la classe	I
Tipo di protezione IEC 601-1	IEC 601-1 equipment type	CEI 601-1 appareil du type	B
Classe 93/42/CEE	93/42/EEC class	93/42/CEE classe	IIb

Sicurezza termica

Per la protezione termica sono presenti tre dispositivi:

- un termostato bimetallico, montato esternamente sul fondo anodico della cuffia (si apre a 67°C);
- un secondo termostato bimetallico all'interno della cuffia, collegato in serie al cavo comune dello statore, che si apre a 80°C.
- un microinterruttore, montato sul lato catodico, azionato dall'espansione del polmone.

Il primo termostato e il microinterruttore sono accessibili all'installatore. Essi dovranno obbligatoriamente essere collegati al circuito di sicurezza dell'impianto. Si osservi che questi termostati devono essere considerati d'emergenza e non come limitatore dell'energia accumulata durante il lavoro normale. Il secondo termostato è da intendersi come ultimo livello di sicurezza, che interviene in caso di mancato funzionamento delle altre sicurezze.

LA PRESENZA DI QUEST'ULTIMO TERMOSTATO NON AUTORIZZA L'INSTALLATORE A NON COLLEGARE I PRIMI DUE !

Thermal safety

Three devices are present for thermal protection:

- one bimetallic thermal switch, fitted externally on the anode end (switches off at 67 °C);
- one bimetallic thermal switch, internally assembled, series connected with stator common cable (switches off at 80°C).
- a microswitch, installed on cathode end, activated by bellows expansion

The first thermal switch and the microswitch are accessible to the installer. They must be connected to the system safety circuits. These devices are emergency devices. They must not be intended as a normal operation limiting devices. The second thermal switch must be considered as the last safety level; it operates in case of unsuccessful functioning of the other devices.

INSTALLER MUST ALWAYS CONNECT THE FIRST TWO DEVICES EVEN IF THE LAST ONE IS PRESENT !

Sécurité thermique

Pour la protection thermique trois dispositifs sont présents:

- un interrupteur thermique à bimétal, monté à l'extérieur sur le fond métallique de la gaine (ouvre à 67°C);
- un deuxième interrupteur thermique à bimétal, monté à l'intérieur de la gaine en série avec le conducteur commun du stator (ouvre à 80°C)
- Un fin de course, monté sur le côté cathode, actionne par l'expansion de la vessie.

Le premier dispositif interrupteur thermique et le fin de course sont accessibles à l'installateur. Ils devront être branchés obligatoirement au circuit des sécurités de l'appareil. Il faut remarquer que ces dispositifs doivent être considérés comme dispositifs d'urgence et non comme limiteurs d'énergie accumulée dans le travail normal. Le deuxième interrupteur thermique est à entendre comme dernier niveau de sécurité, qui intervient en cas de non fonctionnement des autres sécurités.

LA PRESENCE DE CE DERNIER N'AUTORISE PAS L'INSTALLATEUR A NE BRANCHER PAS LES DEUX PREMIERS !

Curve di riscaldamento e raffreddamento della cuffia
Tube-assembly heating and cooling curves
Courbes d'échauffement et refroidissement de la gaine équipée

Con ventilatore / With fan / Avec ventilateur

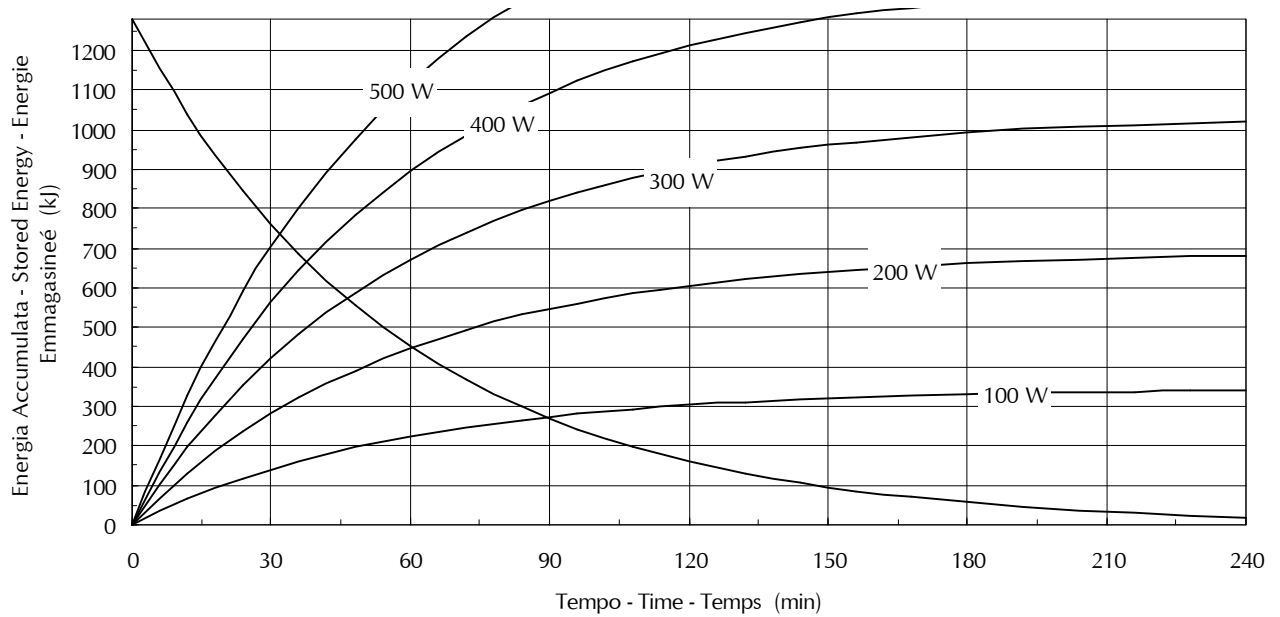

Senza ventilatore / Without fan / Sans ventilateur

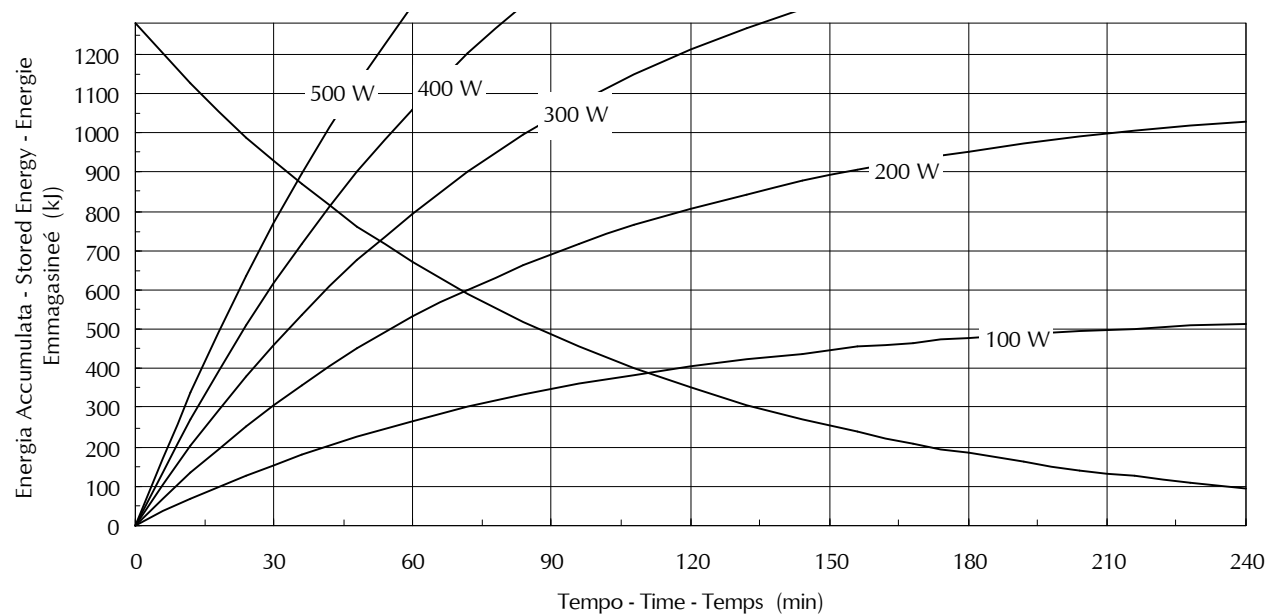

Dimensioni - Outline drawing - Schéma dimensionnel

Vista frontale / Frontal view / Vue frontale

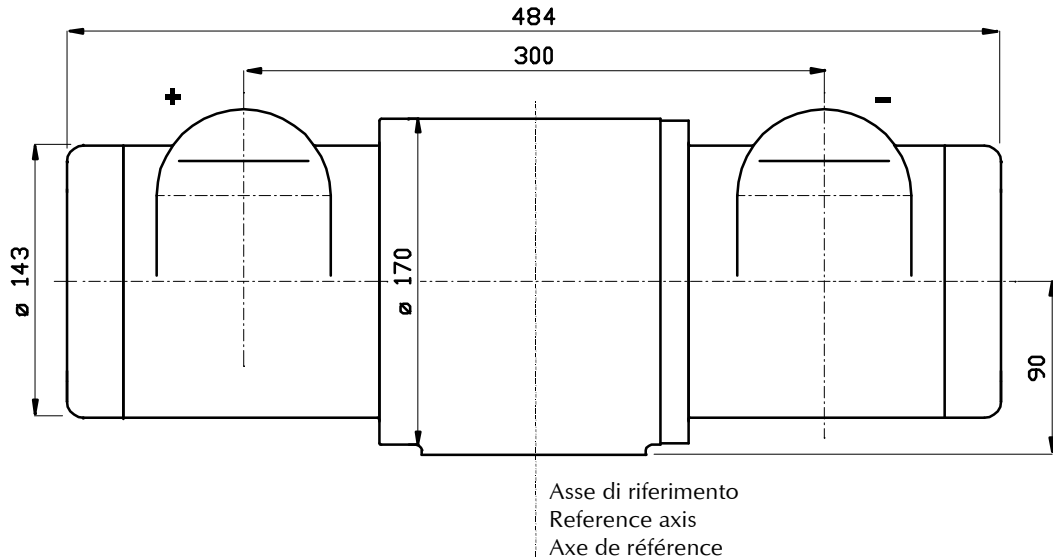

Vista laterale / Housing lateral view / Vue latérale

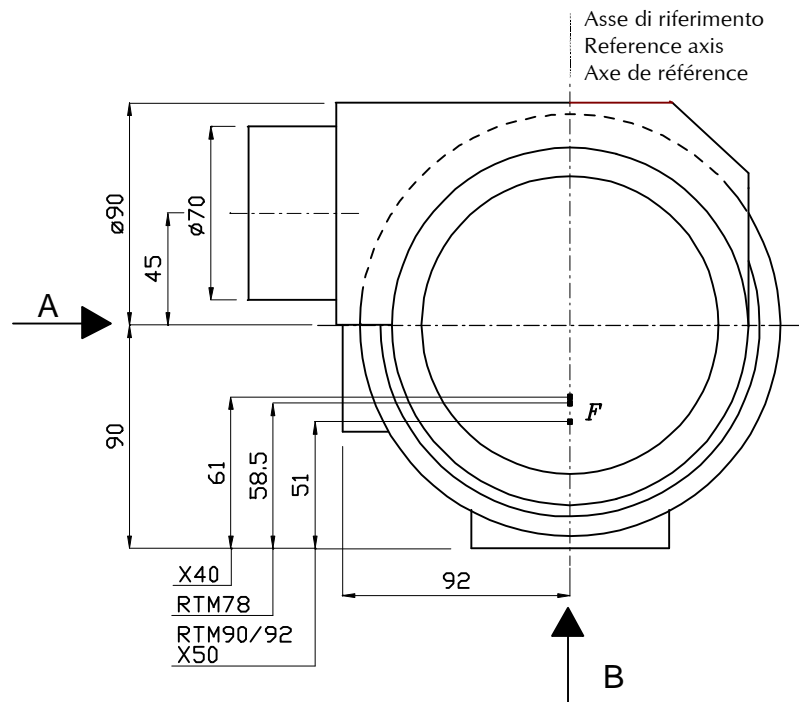

Dimensioni in mm / Dimensions in mm / Dimensions en mm
 F : Posizione delle macchie focali / Focal spots position / Position des foyers

Vista A: fori di fissaggio della guaina / View A: housing fixing holes / Vue A: trous de fixation de la gaine

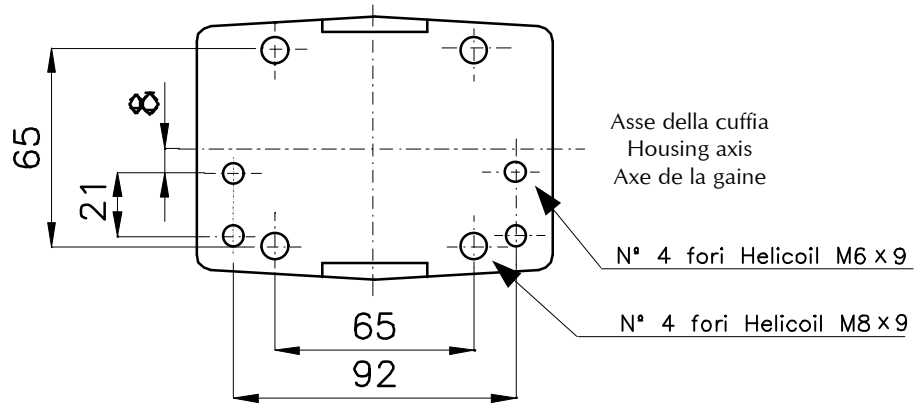

Vista B: fissaggio del limitatore di fascio / View B: collimator fixing holes / Vue B: fixation du collimateur

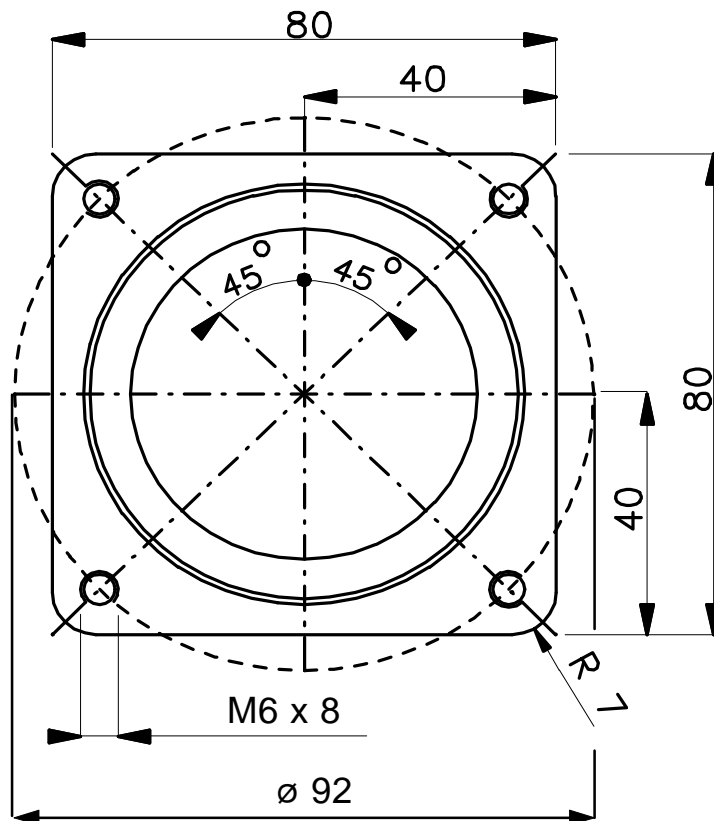

Collegamenti statore - Stator connections - Connexions du stator

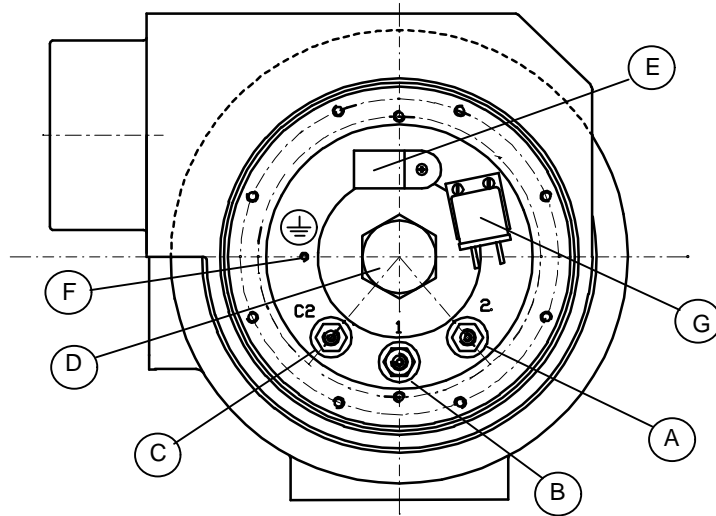

Schema statore / Stator drawing / Plan du stator

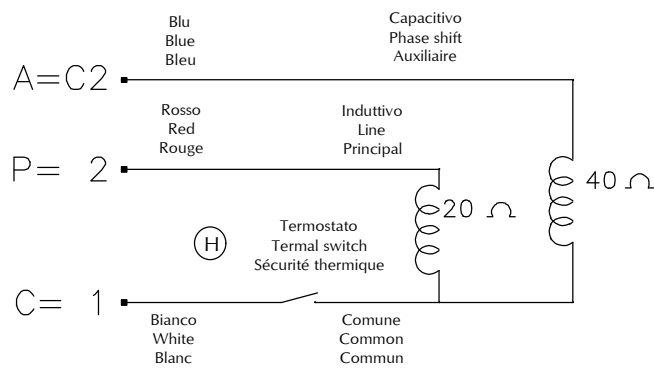

Principale (2=P)	Line (2=P)	Principal (2=P)	A
Comune (1=C)	Common (1=C)	Commun (1=C)	B
Ausiliario (C2=A)	Phase shift (C2=A)	Auxiliaire (C2=A)	C
Tappo olio (non aprire)	Oil plug (do not open)	Bouchon de l'huile (ne pas ouvrir)	D
Passacavo	Cable clamp	Serre- câble	E
Massa	Ground terminal	Borne de masse	F
Termostato esterno normalmente chiuso 5 A, 50 V DC 4 A, 250 V AC apre a: 67° C ± 4° C	External thermal switch, normally closed 5 A, 50 V DC 4 A, 250 V AC opens at: 67° C ± 4° C	Sécurité thermique externe, contact fermé au repos 5 A, 50 V DC 4 A, 250 V AC ouvre à: 67° C ± 4° C	G
Termostato interno normalmente chiuso apre a: 80° C ± 4° C	Internal thermal switch, normally closed opens at: 80° C ± 4° C	Sécurité thermique interne, contact fermé au repos ouvre à: 80° C ± 4° C	H
Interruttore di fine corsa 15 A, 125/250 V AC 0.6 A, 125 V DC	Limit switch 15 A, 125/250 V AC 0.6 A, 125 V DC	Interrupteur thermique 15 A, 125/250 V AC 0.6 A, 125 V DC	

Modifiche alla filtrazione - Modification of filtration - Modification de la filtration

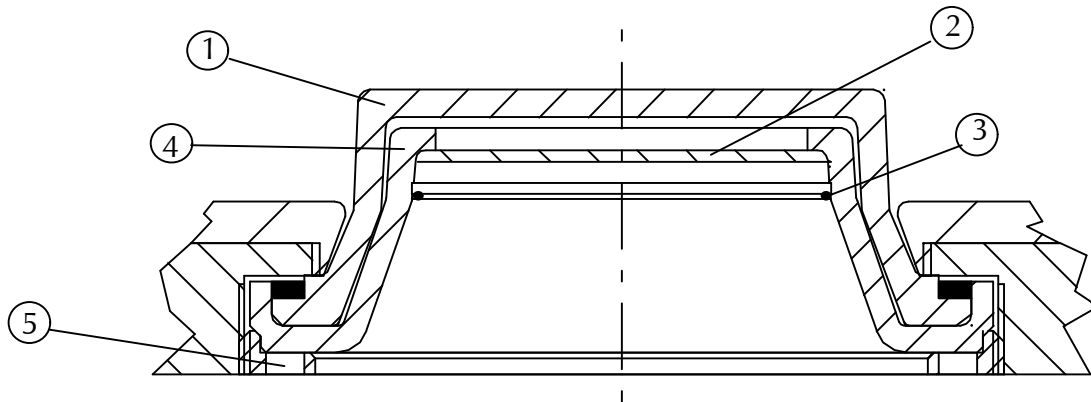

Finestra	Tube-housing window	Fenêtre de la gaine	1
Filtro 0.3 mm Al	Filter 0.3 mm Al	Filtre 0.3 mm Al	2
Molla di fissaggio filtri	Filter clamp	Ressort de fixation du filtre	3
Piombo finestra	Lead window	Fenêtre de plomb	4
Ghiera di fissaggio finestra e cono (non aprire)	Window nut (do not open)	Bague de serrage de la fenêtre (ne pas ouvrir)	5

Attenzione

Il complesso tubo guaina viene fornito con un filtro da 0.3 mm Al già montato al cono finestra e di un filtro addizionale da 1.0 mm Al a disposizione dell'installatore.

Con il solo filtro già montato il complesso tubo guaina risulta conforme alle prescrizioni della normativa (IEC 601.1.3) sulla filtrazione (filtrazione totale di 1.5 mm Al).

E' compito dell'installatore verificare che il complesso radiante risulti conforme alle prescrizioni ad esso relative (filtrazione totale di 2.5 mm Al) utilizzando eventualmente il filtro addizionale a disposizione.

Nota: per montare il filtro addizionale togliere la molla di fissaggio 3.

Warning

The tube assembly is supplied with a 0.3 mm Al filter already installed into the window cone and an additional 1.0 mm Al filter available to the installer.

The tube assembly with the filter already installed complies with the regulations concerning filtration (IEC 601.1.3) (total filtration 1.5 mm Al).

It is the responsibility of the installer to take care that the radiation source assembly complies with the pertinent regulations (total filtration 2.5 mm Al).

If needed the supplied additional filter may be used.

Note: to install the additional filter, first remove the fixation spring 3.

Attention

L'ensemble gaine-tube est fourni à l'origine avec une filtration de 0.3 mm Al intégrée au cône de la fenêtre et une filtration additive de 1.0 mm Al au gré de l'installateur.

En version de base, avec la filtration de 0.3 mm Al intégrée, l'ensemble radiogène est en conformité avec la norme IEC 60.1.13 relative à la filtration (équivalence totale de 1.5 mm Al)

Il est de la compétence de l'installateur de vérifier que l'ensemble radiogène utilisé soit en conformité avec les indications relatives à ces normes et qu'en cas de filtration totale préconisée à équivalence de 2.5 mm Al, d'utiliser la filtration additive mise à disposition à cet effet.

Nota: pour monter le filtre additif: retirer le ressort de fixation 3.

Accessori - Accessories - Accessoires

Accessori forniti	Standard accessories	Accessoires fournis	Cod
Termostato	Thermal switch	Sécurité thermique	0636B67
Filtro 0.3 mm Al montato	Installed filter 0.3 mm Al	Filtre 0.3 mm Al monté	M2709
Filtro 1.0 mm Al addizionale	Additional filter 1 mm Al	Filtre 1.0 mm Al additionnel	M2705
Piombo finestra	Lead window	Fenêtre de plomb	M1321
Grasso al silicone	Silicon grease	Graisse de silicone	0270A10

Accessori opzionali	Optional accessories	Accessoires optionnels	Cod
Flangia regolabile completa	Adjustable flange	Bride de fixation réglable	N0202
Flangia fissa completa	Fixed flange	Bride fixe	N0201
Cravatta	Clamp	Collier de fixation	APA05
Ventilatore + carter + piastra + viti di fissaggio: 230 V AC, 50 Hz, 19 W 230 V AC, 60 Hz, 18 W	Fan +fan casing +backing plate + fixing screws: 230 V AC, 50Hz, 19 W 230 V AC, 60 Hz, 18 W	Ventilateur + boîtier + plaque + vis de fixation: 230 V AC, 50Hz, 19 W 230 V AC, 60 Hz, 18 W	APA51

Vista laterale guaina con ventilatore / Housing lateral view with fan / Vue latérale de la gaine avec ventilateur

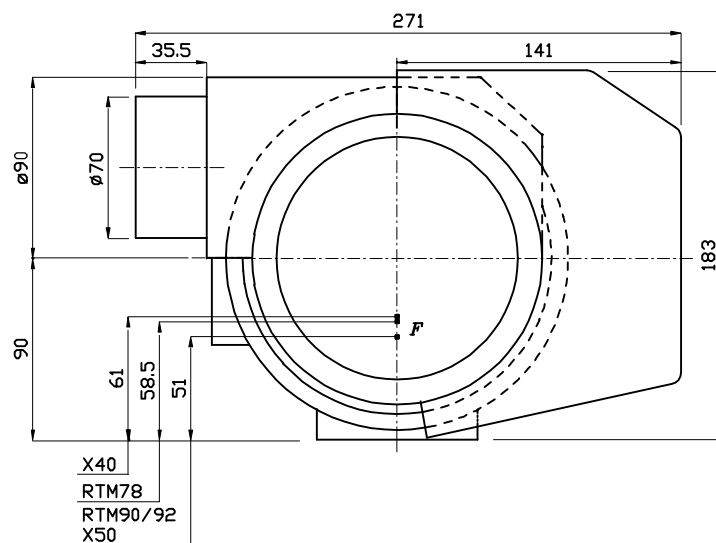

Dimensioni in mm / Dimensions in mm / Dimensions en mm

F : Posizione delle macchie focali / Focal spots position / Position des foyers

Fissaggio della guaina / Housing fixing / Fixation de la gaine

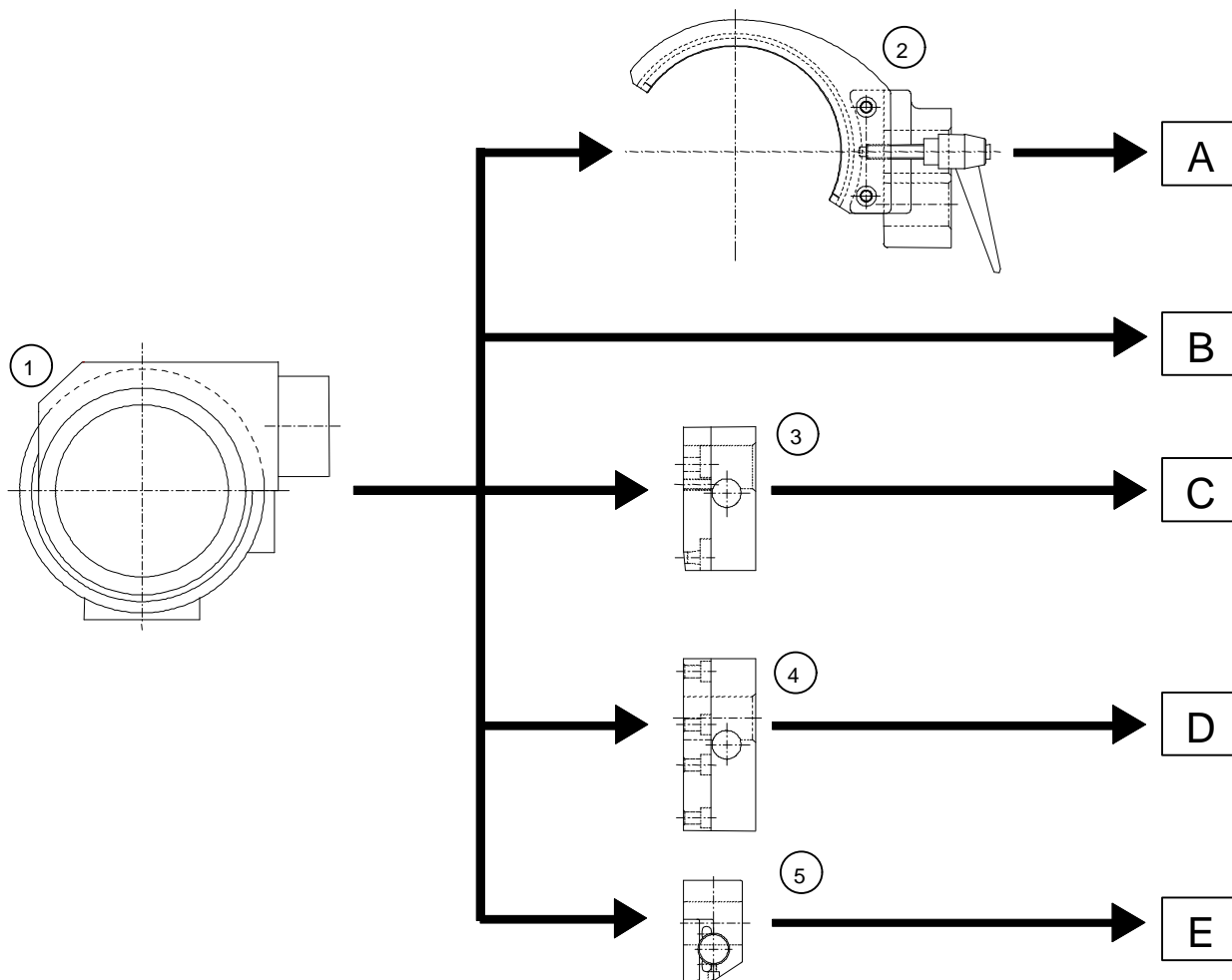

1	Guaina	Tube assembly	Gaine équipée	
2	Cravatta	Clamp	Collier de fixation	APA05
3	Flangia fissa	Clamp flange	Bride de collier	N0200
4	Flangia orientabile	Adjustable flange	Bride de fixation réglable	N0202
5	Flangia cravatta	Fixed flange	Bride fixe	N0203

Cravatta / Clamp / Collier de fixation (APA05) (2 Kg)

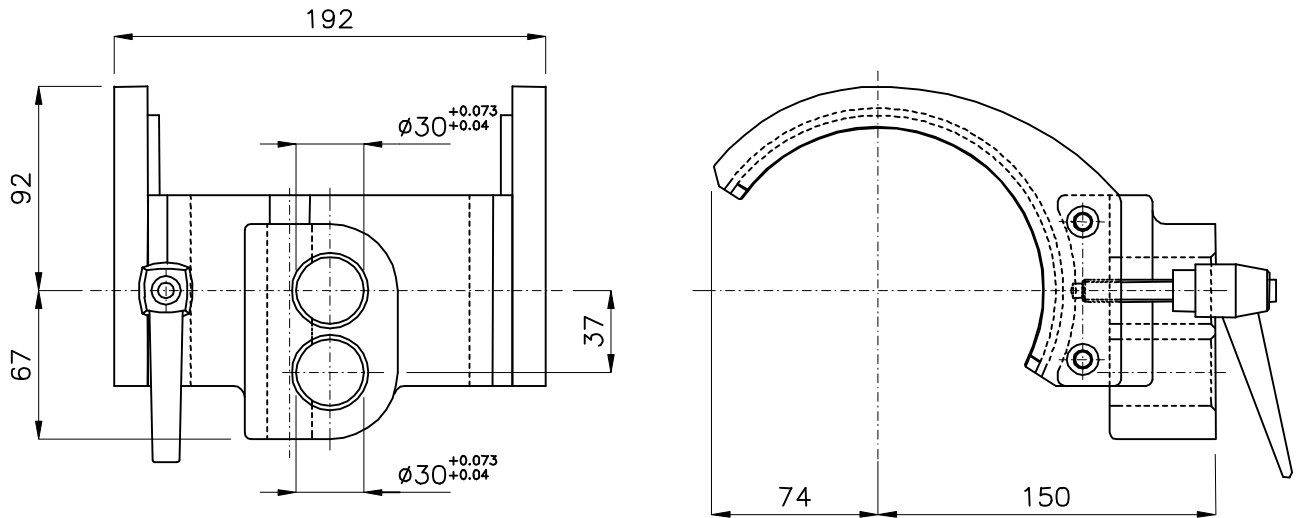

Flangia cravatta / Clamp flange / Bride de collier (N0203)

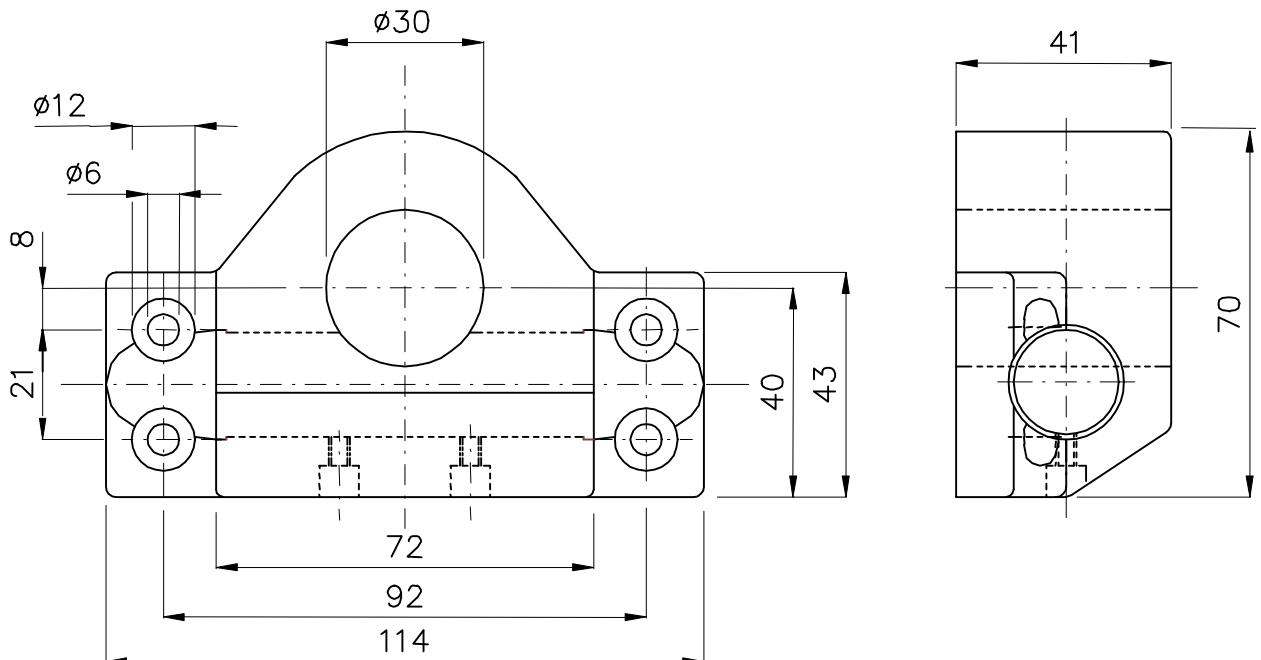



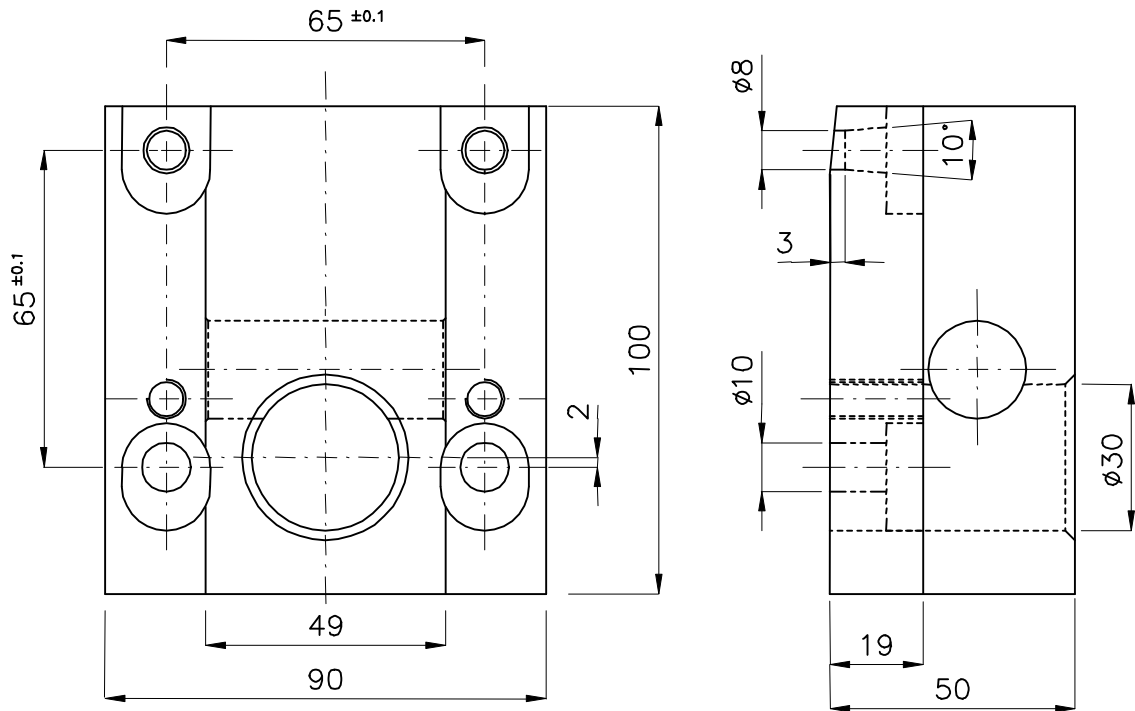

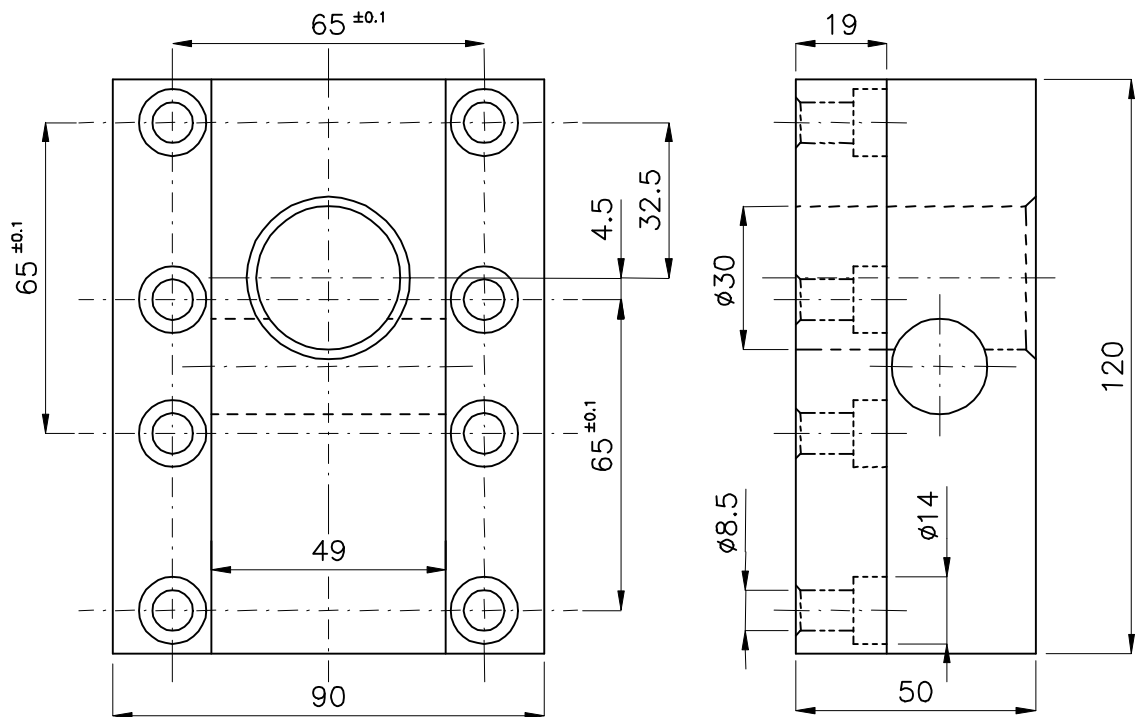

Flangia orientabile / Adjustable flange / Bride de fixation réglable (N0202)



Flangia fissa / Fixed flange / Bride fixe (N0200)



Simbologia - Symbols - Symboles

	Tubo a raggi X	X-ray tube	Tube radiogène
	Guaina a raggi X	X-ray source assembly	Gaine à rayonnement X
	Filtrazione	Filtration	Filtration
	Fuoco piccolo	Small focal spot	Petit foyer
	Fuoco grande	Large focal spot	Grand foyer
	Apparecchio di Tipo B	Type B equipment	Appareil de type B
	Posizione fuoco	Focal spot position	Position des foyers
	Terra di protezione	Protective earth (ground)	Terre de protection
	Tensione pericolosa	Dangerous voltage	Tension dangereuse

**Posizione macchie focali e rotazione anodo
Focal spots position and anode rotation
Position des foyers et rotation d'anode**

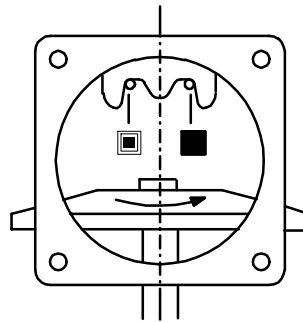

Angolazione caminetti - Housing horn angles - Orientation des embases H.T.

Vista lato anodo / View from anode side / Vue côté anode

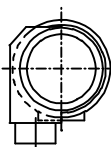
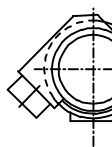
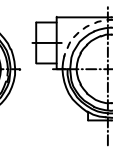
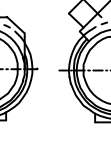
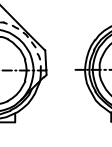
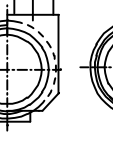
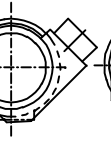
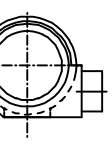
								
Angolo Angle	0°	45°	90°	135°	180°	225°	280°	315°
Codice IAE Code IAE	C52_0	C52_45	C52_90 Standard	C52_135	C52_180	C52_225	C52_280	C52_315